

# LZ-01 Assembly Instruction

Thank you for purchasing the LZ Game Chair. Please check that you received all necessary components and hardware for assembly. Some other tools maybe required (rubber mallet or hammer not provided).

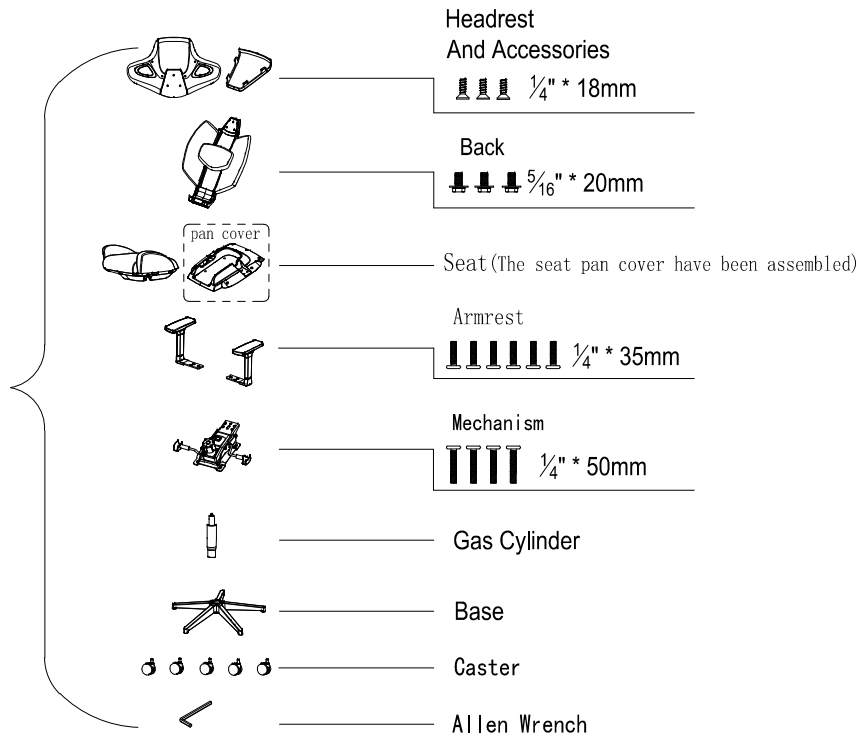

## Assembly Instruction

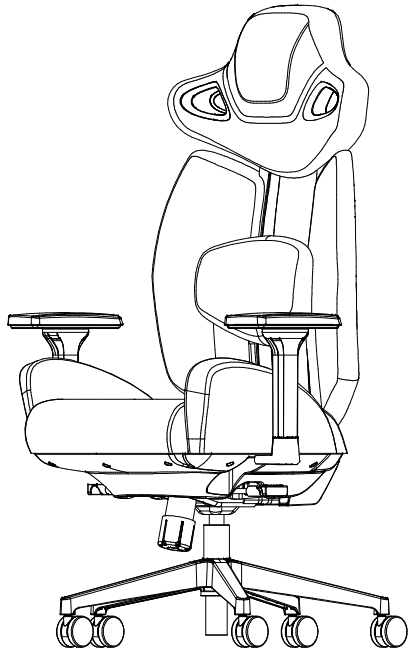
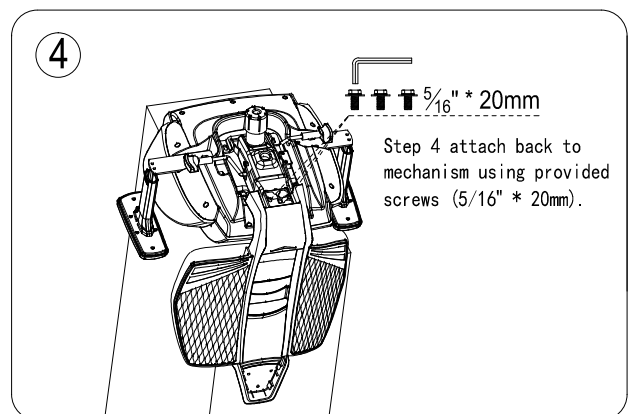
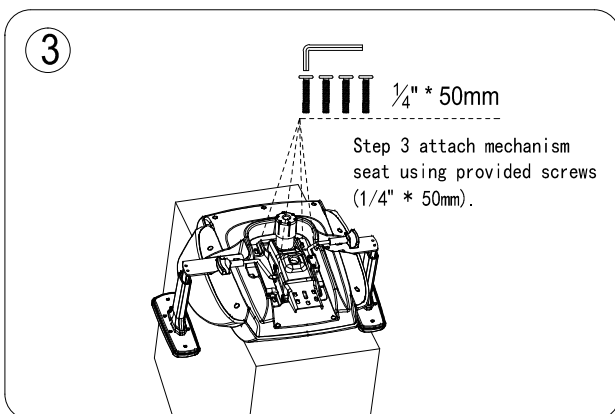
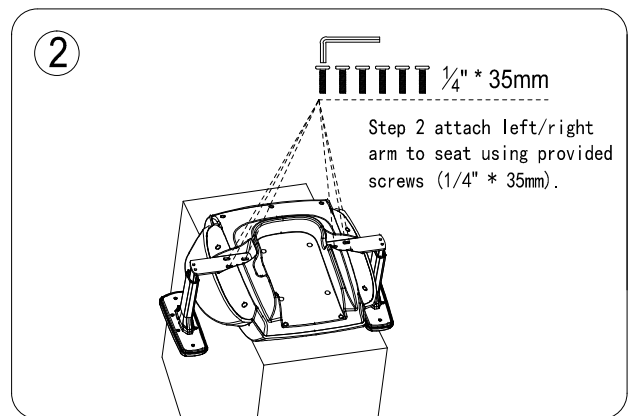
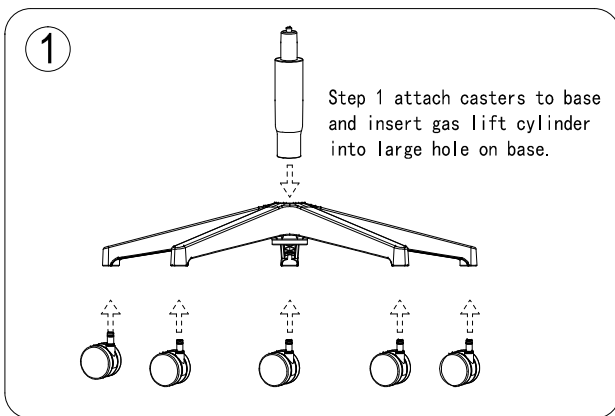

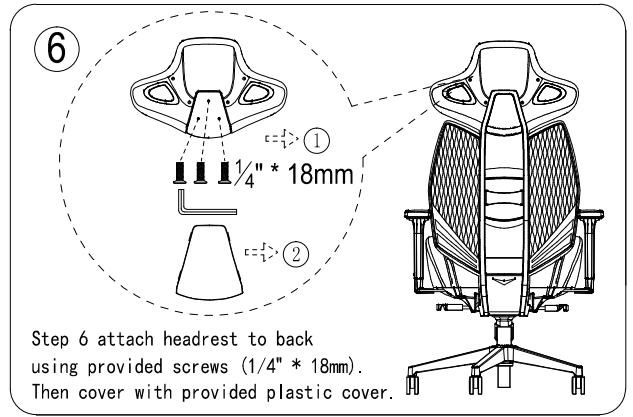
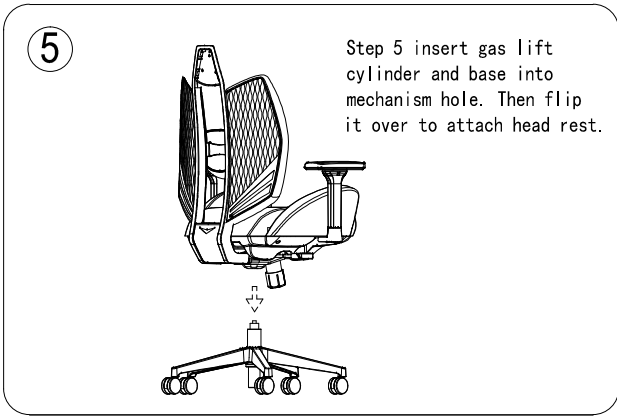

### Instruction of use

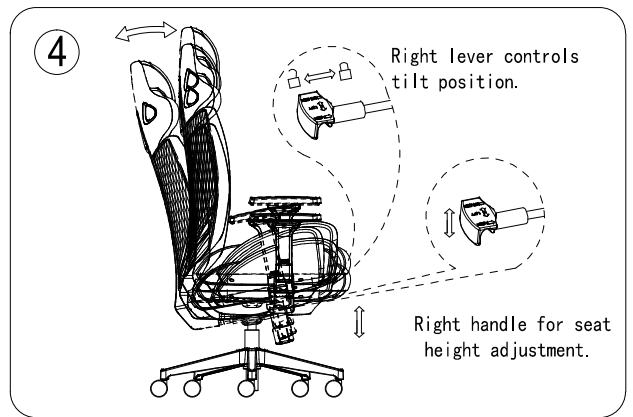
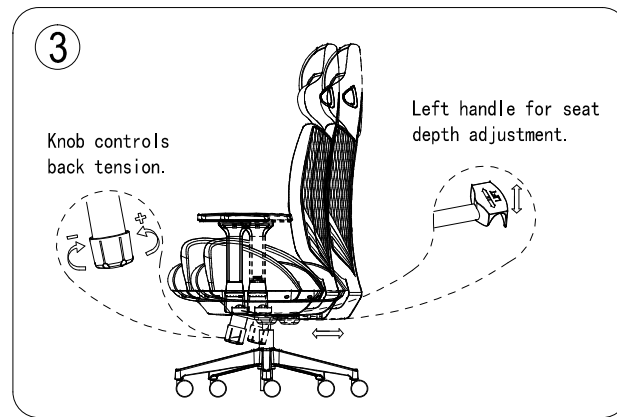
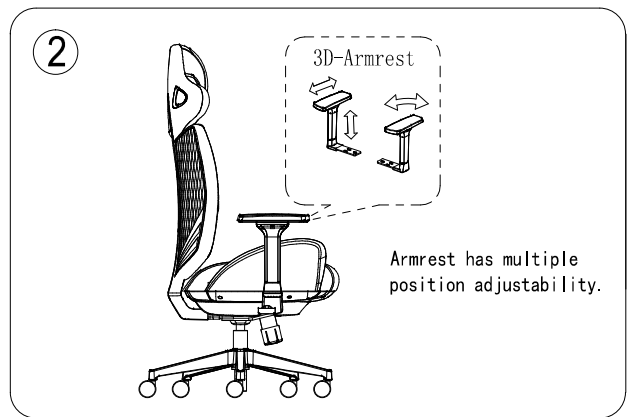
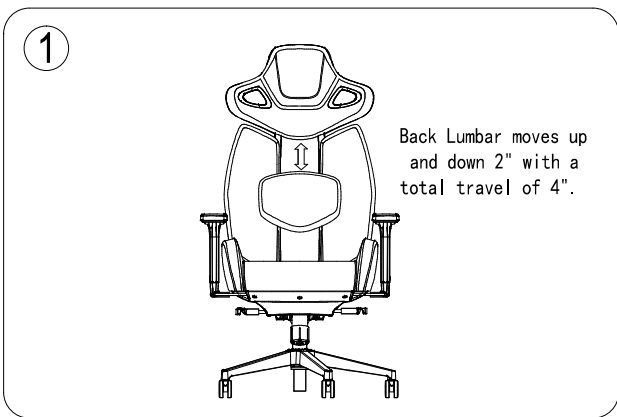

### PREVENTIVE MAINTENANCE AND WARNING:

- DURING ASSEMBLY MAKE SURE TO TIGHTEN BOLTS COMPLETELY.
- DO NOT USE THE CHAIRS UNLESS ALL BOLTS AND SCREWS ARE FIXED TO BE SURE OF SAFETY, CHECK ALL THE BOLTS AND SCREWS EVERY SIX MONTHS.
- THIS PRODUCT ONLY FOR ONE PERSON TO SIT ON AT A TIME.
- DO NOT USE THE CHAIR AS A STEP STOOL OR LADDER.
- IF ANY PART IS BROKEN OR LOST, STOP USING IT UNTIL REPAIRS ARE MADE.
- FAILURE TO FOLLOW THESE WARNINGS MAY CAUSE SERIOUS INJURY.